



AM-212S

LOW NOISE AMPLIFIER



DESCRIPTION

MPI Model AM-212S, Low Noise Amplifier, optimized for UHF SATCOM (DAMA) receiving applications.

FEATURES

Low Noise Figure
High Gain

MPI METROPOLE PRODUCTS, INC
[THE FREQUENCY OF INNOVATION]

P: 540.659.2132 F: 540.659.2133

sales@metropoleproducts.com

2040 Jefferson Davis Highway, Stafford, Virginia 22554

www.MetropoleProducts.com

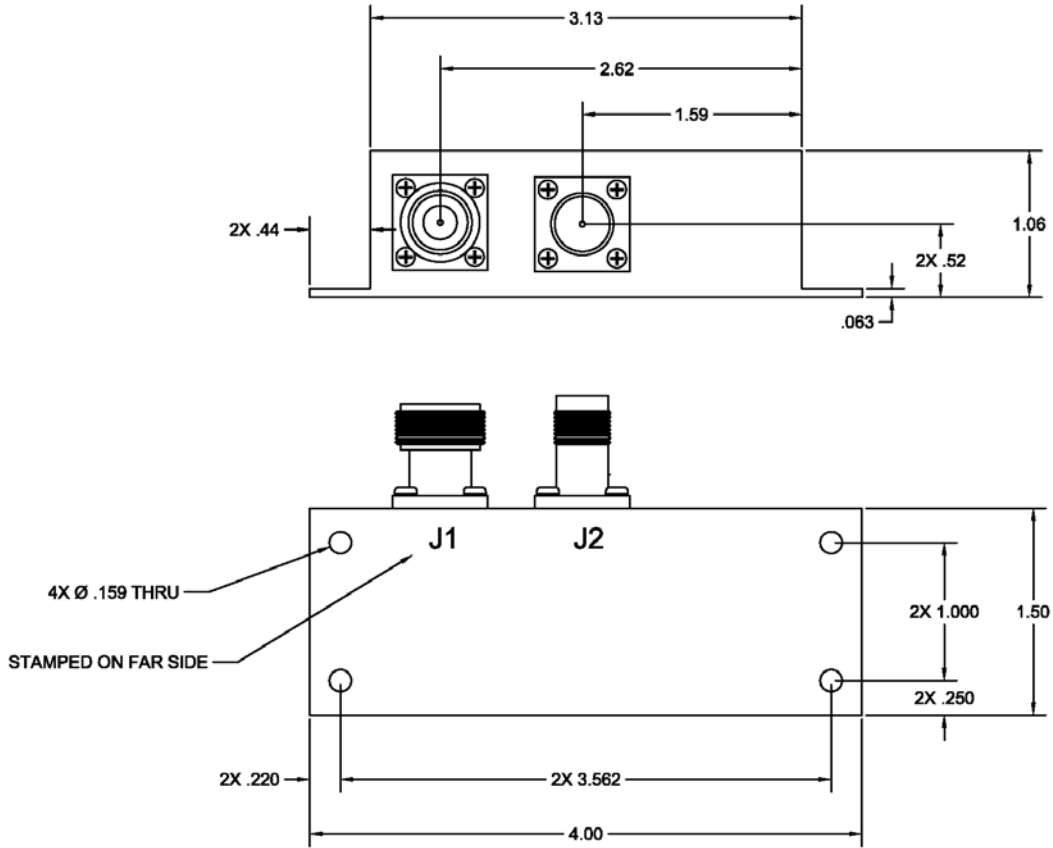

ELECTRICAL SPECIFICATIONS

Bandwidth @ 0.5 dB down	243-270 MHz
VSWR, ref 50 Ohms, Input	2.0:1 max.
VSWR, ref 50 Ohms, Output	1.5:1 max.
Gain, 243-270 MHz	
Minimum	30 dB
Maximum	34 dB
Noise Figure, 243-270 MHz	1.0 dB max.
Input @ 1dB gain compression	-18 dBm min.
Maximum Input Signal, protection level	+30 dBm
Intercept Point, third order	+21 dBm nom.
Power Requirements	
Voltage	+28 VDC nom.
Voltage Range	+22 to +34 VDC
Current	90 mA nom.

GENERAL CHARACTERISTICS

Size, excluding connectors	4.00" x 1.50" x 1.06"
Weight	6 ozs. max.
Connectors	
J1 RF Input	Type N (Female)
J2 RF Output/ DC in	Type TNC (Female)

REV: 5/5/17