

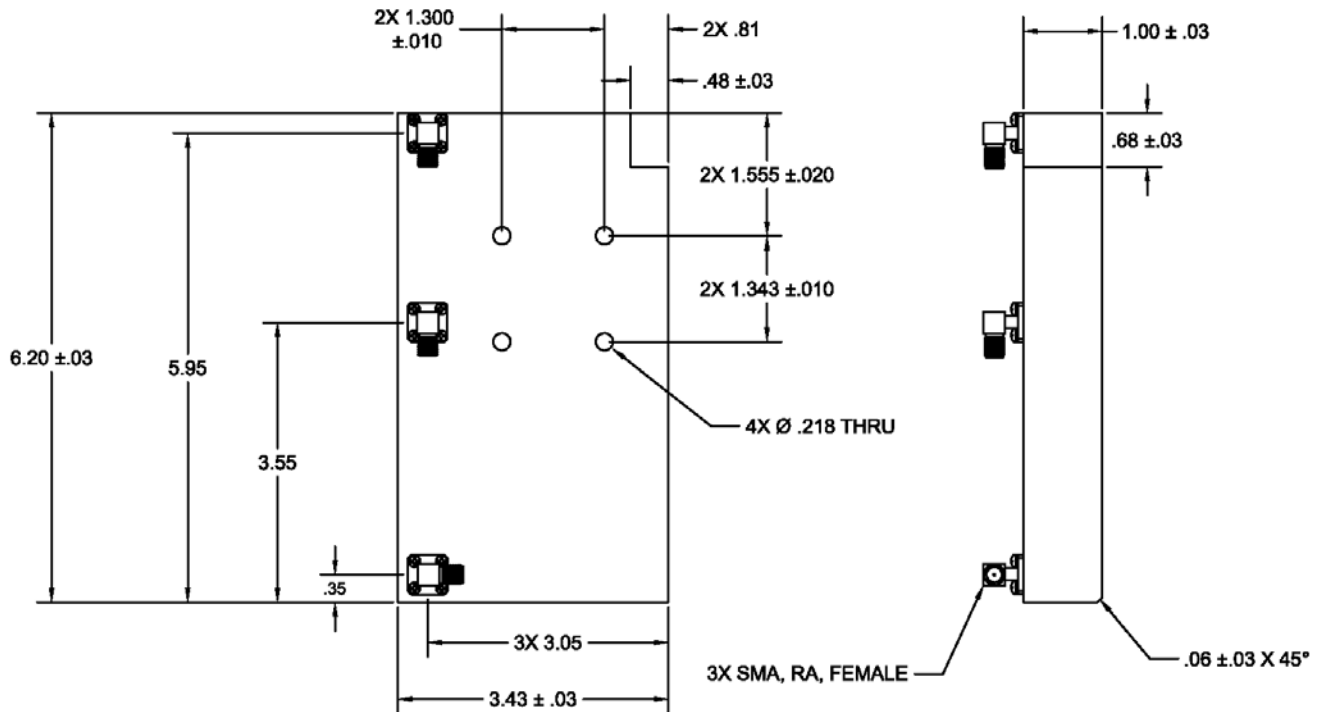

FMA-286

UHF/IFF – GPS DIPLEXER



ELECTRICAL SPECIFICATIONS

CHANNEL 1 (UHF/IFF)

FREQUENCY	
UHF	150-400 MHz
IFF	950-1120 MHz
VSWR	1.5:1 max.
INSERTION LOSS	0.5 dB
ISOLATION	
150-400 MHz	50 dB min.
950-1120 MHz	70 dB min.
POWER HANDLING	
150-400 MHz	100W avg.
950-1120 MHz	1 kW peak @ 10% duty cycle 100 W continuous

CHANNEL 2 (GPS)

Frequency	1215-1239 MHz 1563-1587 MHz
VSWR	1.5:1 max.
ISOLATION	30 dB min.
INSERTION LOSS	
1215 – 1239 MHz	0.7 dB max.
1563 – 1587 MHz	0.5 dB max.

GENERAL CHARACTERISTICS

TEMPERATURE	-40° C to +60° C
WEIGHT	33 oz. nom.
SIZE, excluding connectors	6.20" x 3.43" x 1.00"
CONNECTORS	SMA, Right Angle (female)

REV: 3/14/16